



**MAC - srl**

Sede e stabilimento:  
Via Enrico Mattei, 9 - Loc. MORCIOLA  
61022 VALLEFOGLIA (PU)

Tel. +39 0721 495447  
Fax. +39 0721 495438  
Internet: <http://www.mac-srl.it>  
E-mail: [info@mac-srl.it](mailto:info@mac-srl.it)

Cod. Fisc. - Partita IVA n. 02246440412  
Iscr. Reg. Imprese di Pesaro Urbino n.02246440412  
Cap. Soc. €60.000,00 i.v.



# MANUAL CONTROL BOARD BRAIN 4

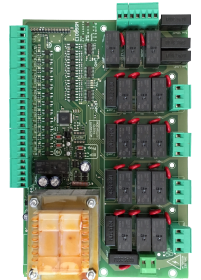

Customer:

Timbre&Signature

Installing Company:

Timbre&Signature

**CAREFULLY READ THE MANUAL BEFORE USE**

<b>ELECTRICAL CONTROL BOARD</b>	<b>3</b>
<b>ELECTRICAL CONNECTIONS OF CONTROL BOARD</b>	<b>4</b>
<b>2.0 TECHNICAL NOTES</b>	<b>7</b>
<b>2.A) INPUTS AP / CH</b>	<b>7</b>
<b>2.B) SAFETY INPUT (S1)</b>	<b>7</b>
<b>SAFETY INPUT (S2)</b>	<b>7</b>
<b>2.C) OUTPUTS</b>	<b>7</b>
<b>2.D) TRAFFIC LIGHTS (SEMAF.)</b>	<b>7</b>
<b>2.E) ELECTRICAL VALVE (ELET.V)</b>	<b>7</b>
<b>2.F) FLASHING LIGHT (LAMP.)</b>	<b>7</b>
<b>2.H) LED LIGHTS</b>	<b>8</b>
<b>2.I) M.E.R.</b>	<b>8</b>
<b>2.J) INSTALLATION</b>	<b>8</b>
<b>2.G) EXIT 24VAC</b>	<b>8</b>
<b>3.0 PROGRAMMING - FUNCTIONING</b>	<b>9</b>
<b>3.A1) RESET OF THE CONTROL BOARD</b>	<b>9</b>
<b>3.A2) SELF NOTICE OF THE LIMIT SWITCHES INPUTS</b>	<b>9</b>
<b>3.B) RADIO CODES PROGRAMMING</b>	<b>9</b>
<b>3.C) RADIO FUNCTION MATCH</b>	<b>9</b>
<b>3.D) CANCELLATION OF A SINGLE RADIO CODE</b>	<b>9</b>
<b>3.F) AUTOMATIC RISE OF BOLLARDS TO THE REVIVAL OF POWER SUPPLY</b>	<b>10</b>
<b>3.F1) PROGRAMMING TIME OF AUTOMATIC RECLOSING</b>	<b>10</b>
<b>3.G) CANCELLATION OF THE AUTOMATIC RECLOSING</b>	<b>10</b>
<b>3.E) CANCELLATION OF A GROUP OF CODES</b>	<b>10</b>
<b>3.H) PROGRAMMING OF THE TRAFFIC LIGHTS WAITING TIME</b>	<b>11</b>
<b>3.I) WORKING TIME OF THE PISTONS PROGRAMMING</b>	<b>11</b>
<b>3.L) CLOCK PROGRAMMING</b>	<b>11</b>
<b>3.M) ACTIVATION OF HYDRAULIC PRESSURE RETENTION</b>	<b>11</b>
<b>3.N) SEQUENTIAL STARTING UP OF THE MOTORS</b>	<b>11</b>
<b>3.O) EXCLUSION OF THE DELAY TIME OF THE LIMIT SWITCH</b>	<b>12</b>
<b>4.0 SAFETY WARNINGS FOR MAINTENANCE AND USE</b>	<b>14</b>
<b>WARRANTY</b>	<b>14</b>
<b>GUIDE FOR THE CAUSES RESEARCH OF SOME DRAWBACKS</b>	<b>14</b>

# ELECTRICAL CONTROL BOARD

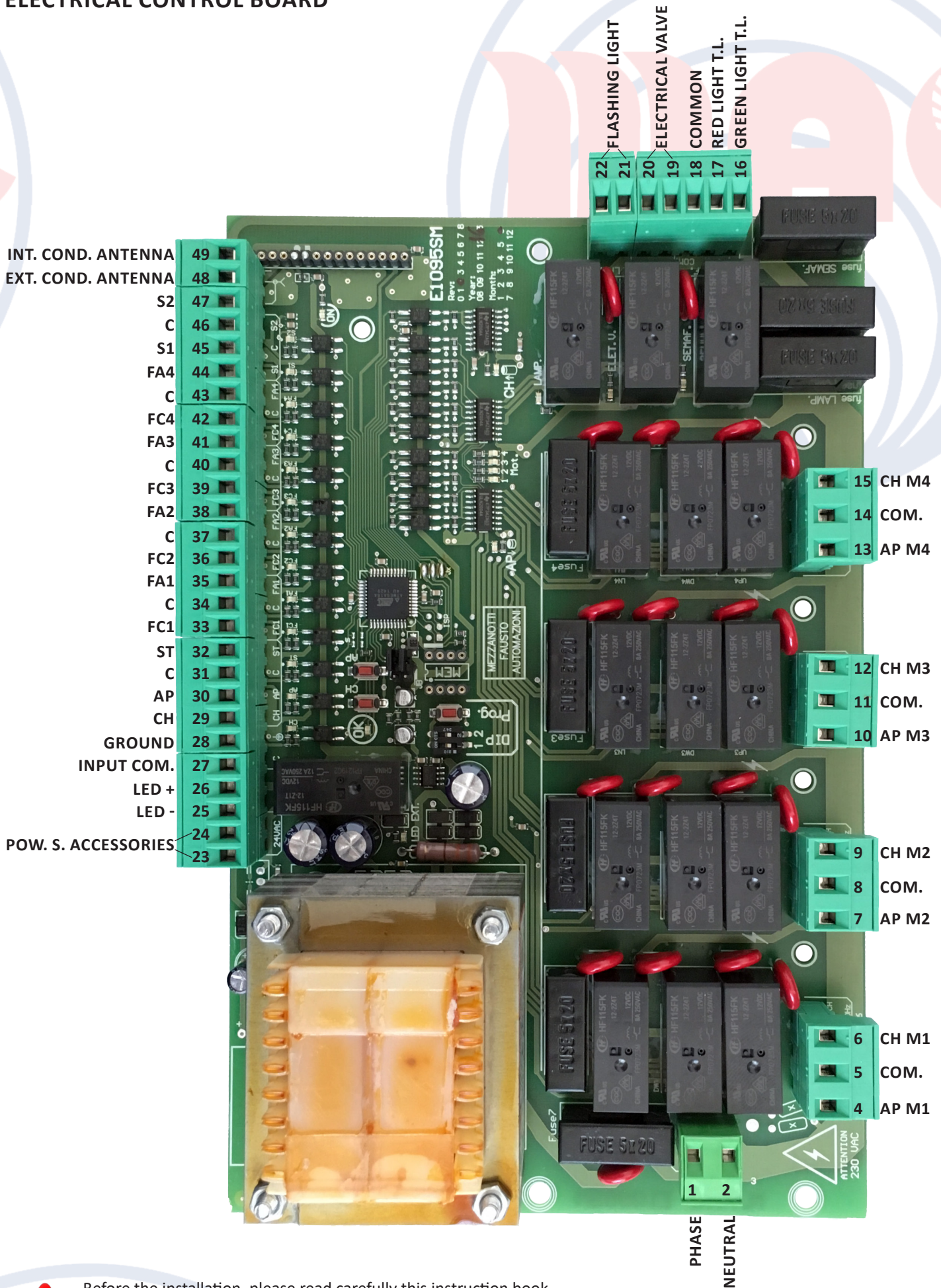

Before the installation, please read carefully this instruction book.

The Company declines every responsibility in case of non-compliance with the laws in force in the Country where the installation is made.

## ELECTRICAL CONNECTIONS OF CONTROL BOARD

SYMBOL	INPUT	CLAMP	CONTACT
<b>CH</b>	CLOSE BUTTON + (CLOCK FUNCTION WITH DIP 1 = ON)	29	NA
<b>AP</b>	OPEN BUTTON	30	NA
<b>C</b>	COMMON + 15 VCC	31	
<b>ST</b>	STOP EMERGENCY	32	NC
<b>Fn</b>	<b>LIMIT SWITCH BOLLARD 1</b>		
<b>FC1</b>	LIMIT SWITCH CLOSE M1 (Fn CLOSED)	33	NC
<b>C</b>	COMMON + 15 VCC	34	
<b>FA1</b>	Finecorsa APRE M1 (Fn OPEN)	35	NC
<b>Fn</b>	<b>LIMIT SWITCH BOLLARD 2</b>		
<b>FC2</b>	LIMIT SWITCH CLOSE M2 (Fn CLOSED)	36	NC
<b>C</b>	COMMON + 15 VCC	37	
<b>FA2</b>	LIMIT SWITCH OPEN M2 (Fn OPEN)	38	NC
<b>Fn</b>	<b>LIMIT SWITCH BOLLARD 3</b>		
<b>FC3</b>	LIMIT SWITCH CLOSE M3 (Fn CLOSED)	39	NC
<b>C</b>	COMMON + 15 VCC	40	
<b>FA3</b>	LIMIT SWITCH OPEN M3 (Fn OPEN)	41	NC
<b>Fn</b>	<b>LIMIT SWITCH BOLLARD 4</b>		
<b>FC4</b>	LIMIT SWITCH CLOSE M4 (Fn CLOSED)	42	NC
<b>C</b>	COMMON + 15 VCC	43	
<b>FA4</b>	LIMIT SWITCH OPEN M4 (Fn OPEN)	44	NC
	<b>SAFETY DEVICE</b>		
<b>S1</b>	SAFETY1 (loop, photocells, sensitive head)	45	NC
<b>C</b>	COMMON + 15 VCC	46	NC
<b>S2</b>	SAFETY2 (sensitive head)	47	NC

## ATTENTION:

**THE LIMIT SWITCHES NOT USED MUST REMAIN OPEN (N.O.)**

OUTPUTS	TERMINAL	NOTES
POWER SUPPLY OF ACCESSORIES	23	24Vac MAX800mA
	24	
LED HEADS MAX n°4	25 (-)	30Vcc MAX120mA
	26 (+)	
COMMON 31-34-37-40-43-46 +15 VCC	27	
GROUND CONNECTION (MANDATORY)	28	
ANTENNA	48	EXTERNAL CONDUCTOR
	49	INTERNAL CONDUCTOR
TRAFFIC LIGHTS WITH TWO LIGHTS (red/green) MAX300W	16	GREEN LIGHT
	17	RED LIGHT
	18	COMMON (neutral)
ELECTRICAL VALVE MAX n°4 (MAX=300W)	19	230Vac MAX300W
	20	
FLASHING LIGHT (WITH BOARD)	21	230Vac
	22	
<b>MOTOR 1*</b>		
OPENING PHASE	4	230Vac MAX500W
COMMON	5	
CLOSING PHASE	6	
<b>MOTOR 2*</b>		
OPENING PHASE	7	230Vac MAX500W
COMMON	8	
CLOSING PHASE	9	
<b>MOTOR 3*</b>		
OPENING PHASE	10	230Vac MAX500W
COMMON	11	
CLOSING PHASE	12	
<b>MOTOR 4*</b>		
OPENING PHASE	13	230Vac MAX500W
COMMON	14	
CLOSING PHASE	15	

POWER SUPPLY CONTROL BOARD	TERMINAL	NOTES
INPUT CABLE COMING FROM THE POWER SUPPLY DISCONNECTOR 230Vac 50Hz	1	PHASE
	2	NEUTRAL
GROUND CONNECTION (MANDATORY)	28	

\*MAX. 500W FOR MOTOR → MAX. DURATION 10 SECONDS

NOTES	mA (interruption)	FUSES
FUSE FOR MOTORS	5000	F1 , F2 , F3 , F4
FUSE FOR ENTRY + SPOOL RELAY	2500	F5
FUSE FOR ACCESORY 24Vac + LED 30Vdc	2500	F6
FUSE FOR POWER SUPPLY	315	F7
FUSE FOR FLASHING LIGHT	2500	Fuse FLASHER
FUSE FOR ELECTRICAL VALVE	2500	Fuse ELECT.VALVE
FUSE FOR TRAFFIC LIGHTS	2500	Fuse TRAFLIGHT

DIAGNOSIS LED	ACRONYM	LED
<i>The LED diagnosis state has been realized at the first ignition of 1 column of the bollards totally lowered. The other bollards haven't been connected to the control board (so their inputs are disconnected)</i>		
It lights when there is electrical network	ON	ON
<b>LED for control board programming</b>	OK	OFF
It flashes after the first minute of ignition (the control board is in safety lock)	OK	OFF
It lights up when the bollards are lowered	AP	OFF
It lights up when the bollards are raised	CH	OFF
It lights up when the motor M1 is on	Mot. 1	OFF
It lights up when the motor M2 is on	Mot. 2	OFF
It lights up when the motor M3 is on	Mot. 3	OFF
It lights up when the motor M4 is on	Mot. 4	OFF
It lights up when the flashing light output is on	LAMP.	OFF
It lights up when the electrical valve output is on	ELET.V	OFF
It lights up when the traffic light is GREEN	SEMAF.	ON
It lights up (described in point 2h) HEAD LIGHTS	LED EXT.	OFF
It lights up with the pushed button / clock	Ing. CH	OFF
It lights up with pushed button / access controls	Ing. AP	OFF
It turns itself off with stop button pushed (stop button with self-holding)	Ing. ST	ON
It lights up when bollard M1 is completely lowered	FC1	ON
It lights up when bollard M1 is completely raised	FA1	OFF
It lights up when bollard M2 is completely lowered	FC2	ON
It lights up when bollard M2 is completely raised	FA2	OFF
It lights up when bollard M3 is completely lowered	FC3	ON
It lights up when bollard M3 is completely raised	FA3	OFF
It lights up when bollard M4 is completely lowered	FC4	ON
It lights up when bollard M4 is completely raised	FA4	OFF
It turns itself off with detected coil / sensitive head detection (see 2.c)	S1	ON
It turns itself off with sensitive head pushed (see 2.c)	S2	ON



**WARNING:**

The grounding cable must be necessarily connected with the predisposed control board clamp: clamp number 28.

The current laws obligate this connection to avoid inopportune starting or missing stops in case of breakdowns (both on input side and output side).

EVERY BOLLARD HAS LABELLED CABLES FOR THE ELECTRICAL CONNECTION WITH THE CONTROL BOARD.

## 2.0 TECHNICAL NOTES

### 2.A) INPUTS AP / CH

The contact to insert in these two inputs are free of tension (N.A.), AP input makes the bollard go down, CH input raises the bollard.

#### **INPUT AP**

It is possible to connect in parallel to this input the following devices:

- N.A. Button
- Emergency vehicles sound recognizer (sirens, police, ambulance, etc.)
- Access control: telepass, number plates reader, magnetic coil, etc.

#### **INPUT CH**

It is possible to connect in parallel to this input the following devices:

- N.A. Button
- Clock contact (optional hardware) (activate the programming)

### 2.B) SAFETY INPUT (S1)

It has been designed for the input of any safety device (also if they are connected in series). This entry allows the reversal of the running direction (only if the bollard is closing the passage).

Connectable devices to this input:

- Magnetic detector with single/double coil
- Active modulated infrared photocells
- Precalibrated pressure switch
- Positive opening limit switch installed under the sensitive head
- Any devices that respects the current laws

PLEASE NOTE: bypass the input if not used.

#### **SAFETY INPUT (S2)**

It has been designed just for specific inputs.

This input guarantees redundancy and safety: using positive limit switches a positive opening of the spools of the relay of the single bollard is ensured. (as in current law).

Connectable devices to this input:

- n°2 positive opening limit switches installed under the sensitive head.

PLEASE NOTE: bypass the input if not used

### 2.C) OUTPUTS

Specific circuit for the ignition the motor in order to improve the performances of the bollard (prevention against malfunctions, route defusing, ex. glued contacts).

### 2.D) TRAFFIC LIGHTS (SEMAF.)

It has been projected to ensure a safe passage of the vehicle in the passage protected by the bollard. The green light will appear when the passage will be free from any obstacle..

### 2.E) ELECTRICAL VALVE (ELET.V)

It has been projected to guarantee the passage even in case of power failure. The electrical valve will make the bollard go down to the ground level. In the version for the MINISTRY OF TRANSPORT the electrical valve is compulsory. The electrical valve is a valve controlled by electricity NA (Normally Open) so that when the diagnostic led is on, it means that the electrical valve is active so the valve is closed.

### 2.F) FLASHING LIGHT (LAMP.)

Use a flasher provided with flashing board. The output of the board is 230 Vdc continuous. The flashing board will let flash the flashing light

When the flashing light is active:

- "Advance warning time" before the starting up of the motors M1, M2, M3, M4
- When the motors are on
- "Waiting time of traffic lights"
- Little flashes followed by a long pause when the bollard is in automatic reclosing.

## 2.G) EXIT 24VAC

It is used for the power supply of the auxiliary devices (ex. Photocells).

## 2.H) LED LIGHTS

It has been projected to supply power to 4 flashing/fixed bright heads according to the movement of the bollard:

- Fixed light when the bollard is up
- Light off when the bollard is down (traffic light time)
- Quick flashing light when the bollard is raising up
- Slow flashing light when the bollard is going down
- Fixed light when the bollard stops

## 2.I) M.E.R.

MECHANICAL ELECTRONIC REDUNDANCY. The control board is provided with a redundancy system that ensures the proper functioning of the bollard even in presence of a breakdown.

Thanks to this system it is possible to check the whole control board to detect any breakdown of a component or a malfunction of an accessory of the system, so that if the automation is provided of an electrical valve allowing the bollard to go down until the ground, it guarantees absolute security.

## 2.J) INSTALLATION

- The control board must be installed in a protected and dry place with its own protection box.
- Install a circuit breaker of type 0,03A, high sensitivity to the supply of the control board.
- Make sure the supply of the control board is 230Vac  $\pm 10\%$  50Hz.
- For the control board, electrical motor, flashing light, traffic lights, electrical valve; use cables with wire not less than 1,5mm<sup>2</sup> up to 50m of distance; for limit switches and accessories of command and safety use cables with wires of 1mm<sup>2</sup>. For distances of more than 50 meters use the appropriate wires with the suitable section for the installation. Note: for applications such as lights, cameras etc. use static relays.
- The installation should be made by competent staff and in compliance with the legislation in force.
- Before starting the installation verify the integrity of the control board.
- The installation, the electrical connections and the regulations must be done "by the book".
- Packaging Materials (cardboard, plastic, polystyrene, etc.) should not be dispersed into the environment.
- Do not install the control board in environment exposed to danger or disturbed by electro-magnetic fields. The presence of gas or flammable smokes is a great danger for safety.
- Provide on the supply network a protection for extra tensions, a switch/ disconnecting switch and/or differential suitable with the product and with the current law.
- The constructor declines every responsibility if other devices and/or components incompatible with the product for integrity are installed, safety and functioning of the product.
- For reparation or substitution only original spare parts must be used.
- The installer must give all the information related to the functioning, maintenance and use of the single parts and of the system in its entirety following the Directive Machine (see laws EN 12635, EN 12453 and EN 12445).



## 3.0 PROGRAMMING - FUNCTIONING

### 3.A1) RESET OF THE CONTROL BOARD

This function allows to go back to the basic programming;

Working time 8 seconds

Traffic lights waiting time 10 seconds

Limit switch delayed of 200 ms

Automatic reclosing excluded

Basic radio code: button 1 of a TX type 53200 with DIP 1,3,5,7,9 in ON and DIP 2,4,6,8,10 in OFF

RESET PROCEDURE:

- 1) Push and keep pushed the button PROG (II led OK and led EXT are fixed on)
- 2) After about 3 seconds the led OK starts to flash quickly
- 3) Release the button PROG, the led OK keeps flashing.
- 4) Open the contact to entrance STOP (if there is, push the stop button) for at least 5 seconds.  
The led OK starts to flash quickly.
- 5) Reclose the contact to entrance STOP
- 6) When the led OK ends to flash and it is off, the reset has been completed.

### 3.A2) SELF NOTICE OF THE LIMIT SWITCHES INPUTS

When the control board is on, the microprocessor checks the limit switches inputs.

If during the starting up of the control board the limit switches of the motors 2,3,4 are not on the inputs, the microprocessor excludes automatically the inputs and the motors 2,3,4 will not be moved from the control board.

Note: Thanks to this mechanism it isn't necessary to bridge the inputs of the limit switches that are not used.

### 3.B) RADIO CODES PROGRAMMING

PROCEDURE:

- 1) Push 1 time the PROG button (the led OK and EXT are on, fixed)
- 2) Send the radio code keeping a distance of at least 150cm from the control board.
- 3) If the code has been memorized, the OK led flashes 1 time.
- 4) If there are other codes to be memorized, repeat from point 3
- 5) Push 2 times the PROG button (the OK led turns itself off) to exit from the radio codes programming

### 3.C) RADIO FUNCTION MATCH

If no input is active during the sending of the code to be memorized (point 3), the command is matched with the "Only Open" function for all the four pistons.

To match the Start function (OPEN/CLOSE) with radio command for all the four pistons, push the AP and CH buttons simultaneously

To match the radio command with piston 1, push the AP button while sending the code.

To match the radio command with piston 2, just open the SIC1 contact while sending the code.

To match the radio command with piston 3, just open the SIC2 contact while sending the code.

To match the radio command with STOP function (for all the pistons), activate the STOP input (open the contact) while sending the code.

### 3.D) CANCELLATION OF A SINGLE RADIO CODE

PROCEDURE:

- 1) Push 2 times the PROG button (the led OK is on, whereas the leds EXT flash)
- 2) Send the radio code to be cancelled
- 3) If the led OK flashes 3 times it means that the code has been cancelled, instead if it flashes 1 time slowly, it means that the radio code isn't present in memory
- 4) If there are other codes to be cancelled, repeat from point 3
- 5) Push 2 times the PROG button to exit from the radio codes cancellation (the OK led and the external leds turn themselves off)

### 3.E) CANCELLATION OF A GROUP OF CODES

It allows to delete all the same type codes with a single operation.

PROCEDURE:

- 1) Push 2 times the PROG button (the led OK is on, whereas the leds EXT flash)
- 2) Select the group to be cancelled:
  - AP+CH button (push simultaneously) -> canc. all the OPEN/CLOSE codes
  - AP button -> canc. all the codes for PISTON 1
  - CH button -> canc. all the codes for PISTON 2
  - SIC1 button -> canc. all the codes for PISTON 3
  - SIC2 button -> canc. all the codes for PISTON 4
  - STOP entry -> canc. all the STOP codes
- 3) The OK led quickly flashes during the cancellation
- 4) When the OK led turns itself off, the procedure is finished.

### 3.F) AUTOMATIC RISE OF BOLLARDS TO THE REVIVAL OF POWER SUPPLY

At the revival of power supply the control board commands the automatic rise of all the pistons only if the time of automatic reclosing has been programmed.

Check the points 3.f1 and 3.f2 for the programming and the cancellation of automatic reclosing.

#### 3.F1) PROGRAMMING TIME OF AUTOMATIC RECLOSING

PROCEDURE:

- 1) Push and keep pushed the PROG button (the led OK and EXT are on, fixed)
- 2) After about 3 seconds the led OK starts to flash
- 3) Release the PROG button, the led OK keeps flashing
- 4) Push and keep pushed the CH button for the time you wish to memorize
- 5) When the CH button is released the led OK turns off and the procedure is finished

**WARNING:** Programming the time of automatic reclosing, also activates the automatic rise at the revival of power supply. (Check point 3.f).

During the normal functioning the automatic reclosing can be excluded sending a START/STOP command during the pause or activating the EMERGENCY STOP.

#### 3.G) CANCELLATION OF THE AUTOMATIC RECLOSING

PROCEDURE:

- 1) Push and keep pushing the PROG button (the led OK and the leds EXT are on, fixed).
- 2) After about 3 seconds the led OK starts to flash
- 3) Release the button PROG, the led OK keeps flashing.
- 4) Open the contact to the input SIC2
- 5) The OK led flashes to signal that the cancel process is happening
- 6) When the OK led turns off the procedure is finished

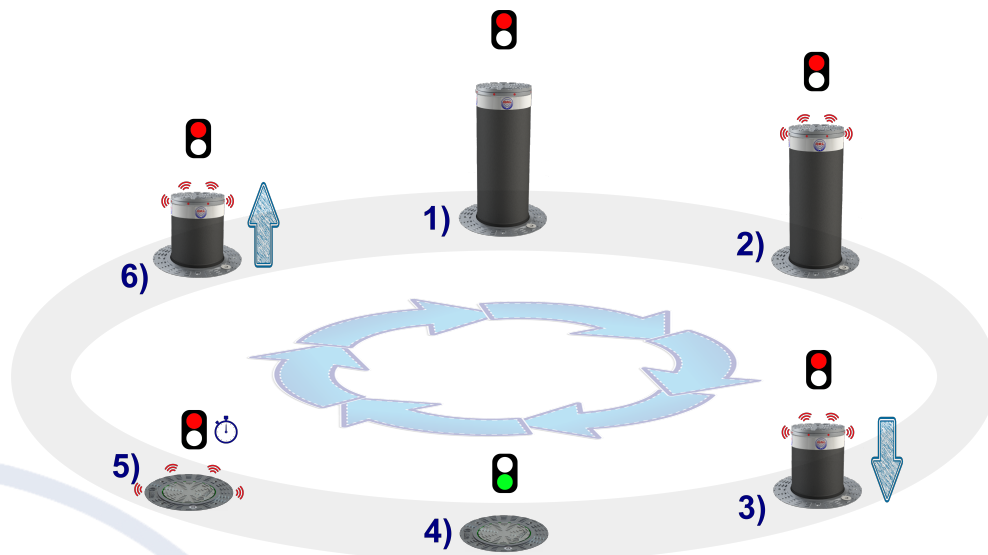

IMAGE A

**WARNING:** Deleting the time of automatic reclosing, also deactivates the automatic rise at the revival of power supply. (Check point 3.f).

### **3.H) PROGRAMMING OF THE TRAFFIC LIGHTS WAITING TIME**

The waiting time of the traffic light is the available time for a vehicle to cross and free the passage from when the traffic light is red until the bollard starts its climb.

Meanwhile, the leds incorporated in the head keep flashing (see image "A" at page 10, point 5.)

In order to define the waiting time, it is necessary to time how much a vehicles takes for crossing and freeing the passage. (see image "A" at page 10)

**PROCEDURE:**

- 1) Push and keep pushed the PROG button (the led OK and the leds EXT are on, fixed)
- 2) After about 3 seconds the led OK starts flashing.
- 3) Release the PROG button, the led OK keeps on flashing.
- 4) Push and keep pushed the AP button for the time you wish to memorize.
- 5) When the AP button is released, the OK led turns off and the procedure's finished

### **3.I) WORKING TIME OF THE PISTONS PROGRAMMING**

**PROCEDURE:**

- 1) Push and keep pushed the PROG button (the led OK and the led EXT are on, fixed)
- 2) After about 3 seconds the led OK starts flashing
- 3) Release the PROG button, the led OK keeps flashing
- 4) Only open the contact to input SIC1 for the time you wish to memorize
- 5) When the contact S1 is closed, the led OK turns off and the procedure is finished

**WARNING:** Use the condenser 20 $\mu$ F for the connections of the motors

- To obtain a better starting of power use the following condensers: 20 $\mu$ F, 25 $\mu$ F.

### **3.L) CLOCK PROGRAMMING**

To activate the clock logic, the DIP1 must in ON.

Note: when this logic is activated you must connect the clock contact without power instead of the input CH (clamps 31-29).

Thanks to this function the road will be open until the contact of the clock is closed and it will close when the clock contact is open. In case of power failure, at the revival of power the control board guarantees the reopening or the reclosing even if the clock has inverted while the control board was off. When the clock contact is closed, the pause management is excluded. If during the automatic reclosing of the clock, the SECURITY 1 intervenes, the bollard reopens and it will try to reclose after 5 minutes. The closing attempts will continue until the bollard isn't closed or until the user's command. If it is pushed with an opening button from a transmitter or from a control board, the bollard does a safety lowering, if the clock contact is still open, the bollard will do the rise again (The control board before doing the rise always verifies all the securities, and and always verifies the pause time and the waiting time of the traffic light).

### **3.M) ACTIVATION OF HYDRAULIC PRESSURE RETENTION**

To activate this function, DIP 2 must be in "ON".

When the system is in "CLOSE" state, the control board checks the position of closing limit switches.

If the limit switches have inverted their state, due to pistons lowering, the control board commands the closing of the bollard. The control is done every 10 minutes and the forced closing lasts up to the reaching of the limit switches or to a maximum of 3 seconds. Before the forced closing the bollard makes some signalling flashes (examples: quick start flash of sensitive head +led ORION)

The flashing light doesn't work during the forced closing.

During the forced closing the securities S1 and S2 don't order the inversion but only the stop.

### **3.N) SEQUENTIAL STARTING UP OF THE MOTORS**

With this function the motors don't start up at the same time but in sequence:

M1 >> M2 >> M3 >> M4.

**PROCEDURE:**

- 1) Turn off the control board
- 2) Insert the jumper in the position JA.



### 3.0) EXCLUSION OF THE DELAY TIME OF THE LIMIT SWITCH

Usually the motors stop after 250ms from the opening of the contact of the limit switches (JB open).





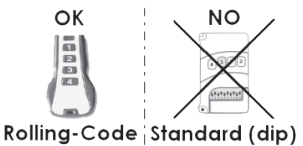
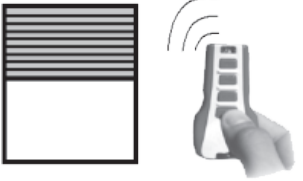

Thanks to this procedure it is possible to exclude the delay stopping the motors as soon as the limit switch contact is opened (JB close).

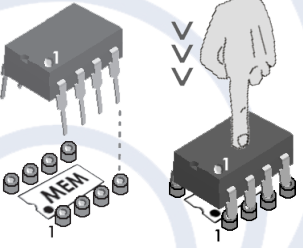
#### PROCEDURE:

- 1) Turn off the control board
- 2) Insert the jumper in the position JB

RADIO CONTROL REMOTE PROGRAMMING	OPERATIONS	PICTURES
<p>This procedure allows to guarantee a new radio code without directly operating on the board.</p> <p>The programming operations occur all by radio using a remote control already programmed on the control board.</p> <p>If there are more codes to be memorized, it is necessary to repeat every time this procedure from the beginning.</p> <p>This function is available only if in the control board are only memorized Rolling-Code codes.</p>	<p>The function of the new radio code can be selected during the programming following the same criterion for the standard memorisation.</p>	 <p>Rolling-Code   Standard (dip)</p>
	<p>1. Send a command to the control board with a remote control IRIS RC type already added in memory.</p>	
	<p>2. Within 8 seconds, push simultaneously 1 and 3 buttons of the IRIS RC remote control used in the previous point. The control board is entered into programming.</p>	
	<p>3. Within 8 seconds, send the new radio code of the remote control to be memorised (Rolling-Code type). If no code is sent, the control board exits from the programming after 8 seconds automatically.</p>	
	<p>4. Check that the new code memorised perfectly works, otherwise repeat the procedure.</p>	

EXTERNAL MEMORY	OPERATIONS	PICTURES
<p>If the external memory module is inserted on the control board, it is possible to expand the memory capacity of the radio codes from 160 standard codes and 60 Rolling-Code to 8000 standard codes and 2000 Rolling-Code.</p> <p>When the control board detect the presence of the external memory, the internal memory management is automatically excluded. It means that the radio codes memorized before the insertion of the new don't work.</p> <p>If it is necessary to recover the codes memorized previously, the procedure of memory copy INT &gt;&gt; EXT. must be done.</p>	<p>1. Turn off the control board and insert the memory module on the base 8 pin [MEM] following the warnings below:</p> <p>Handle the external module with care. Don't wet it, don't drop it, don't expose it to electromagnetic fields or to heat sources.</p> <p>The assembly on the board must be done respecting the component polarity. The pin n°1 is indicated with a white circle.</p> <p>2. Place the module on the base and check that all the pins are aligned with the related holes Insert the module pushing it toward the board. Be careful not to bend the pins.</p>	 
	<p>Before memorising the new radio codes, make a copy of the internal memory on the external memory, or do the reset procedure.</p>	

COPY MEMORY INT----->EXT :	OPERATIONS	IMAGES
<p>This function is usable only if there is an external memory module. When the control board detects the presence of the external memory, internal memory management is automatically excluded. It means that the radio codes memorised before the input of the new memory don't work.</p>	<p>Turn off the control board Keep pushed the PROG. Button</p>	<p>SPEGNERE LA CENTRALE</p> 
<p>This procedure allows to recover the codes memorised in the internal memory by making a copy of the codes from the internal memory to the external memory.</p>	<p>Turn on again the control board. The OK led flashes two times quickly and then remain fixed</p>	<p>ACCENDERE LA CENTRALE</p> <p>ACCESO</p> 
<p>Wait until the led begins to flash again (around 3sec)</p>	<p>Attendere</p> 	<p>LAMPEG.</p> 
<p>When the OK led stops to flash and turns itself off, the copy is finished. (copy time: around 60sec)</p>	<p>Attendere</p> 	<p>SPENTO</p> 

## 4.0 SAFETY WARNINGS FOR MAINTENANCE AND USE

### WARNINGS

These warnings are integral and essential parts of the electronics and they are to be given to the final user. So it is necessary to keep this manual. Read carefully the instruction book which gives important indications about the installation. The wrong installation or the improper use of the control board may be a source of serious danger.

### MAINTENANCE

To guarantee the efficiency of the control board professional staff must make the maintenance in times decided by the installer, by the producer and by the legislation in force. The operations of installation, maintenance, reparation and cleaning must be documented. This documentation is to be kept by the user.

### FOR THE USER

Read carefully the instructions and the documents enclosed. The product must be used according to the use designed by the constructor. Any other use is to be considered improper and dangerous.

In case of maintenance, cleaning, breakdown or malfunction of the product, turn off the power supply and avoid any attempt of intervention except when indicated. Call MAC s.r.l. staff before any maintenance or sending of damaged/broken material.

### WARRANTY

The warranty is twenty-four (24) months starting from the selling date of the control board. It decays in case of: negligence, mistake or wrong use of the product, use of non-compliance accessories to the specifics of the builder, tampering operated by the customer or by a third party, natural causes (lightnings, floods, fire, etc.), vandalism acts, changes in the environmental conditions in the installation place. The warranty does not include, moreover, the parts subject to wear. (batteries, oil, etc.). The purchase of the product implies the complete acceptance of the general sale conditions.

## GUIDE FOR THE CAUSES RESEARCH OF SOME DRAWBACKS

N	DRAWBACKS	PROBABLE CAUSES	HYPOTESIS OF FAULT	SOLUTIONS
1	BOLLARD DOESN'T RAISE (wrong connections)	Wrong sense of rotation  Reversed limit switches  Lack of power supply  Control board broken  Fuses damaged	Wrong connection of electrical motor  Wrong limit switch connection  Sectional switch open  Control board broken  High absorption peak  Short circuit on the motor line, electrical valve, inputs, output24Vac, traffic light	Rewire the electrical motor on the control board (reverse rise/fall wires)  Rewire magnetic limit switches (reverse limit switch close with open-rise)  Reactivate sectional switch  Replace the control board  Replace the fuse with others appropriate  Check and fix the breakdown
2	BOLLARD DOESN'T RAISE COMPLETELY (during the rise the bollard stops)	Magnetic limit switches remain closed (lights FC and FA on about MOT)	Wrong programming of working time  Magnetic limit switch out of the reading zone of the magnet	Program again the working time  Establish the right position for limit switches reading between the magnet and the sensor (moving close the magnetic limit switch)

230 Vac 50Hz

- Power supply accessories:
- n°2 Pairs of photocells
  - n°1 Radio receiver
  - n°1 Emergency sound recognizer
  - n°1 Button "Break the glass"

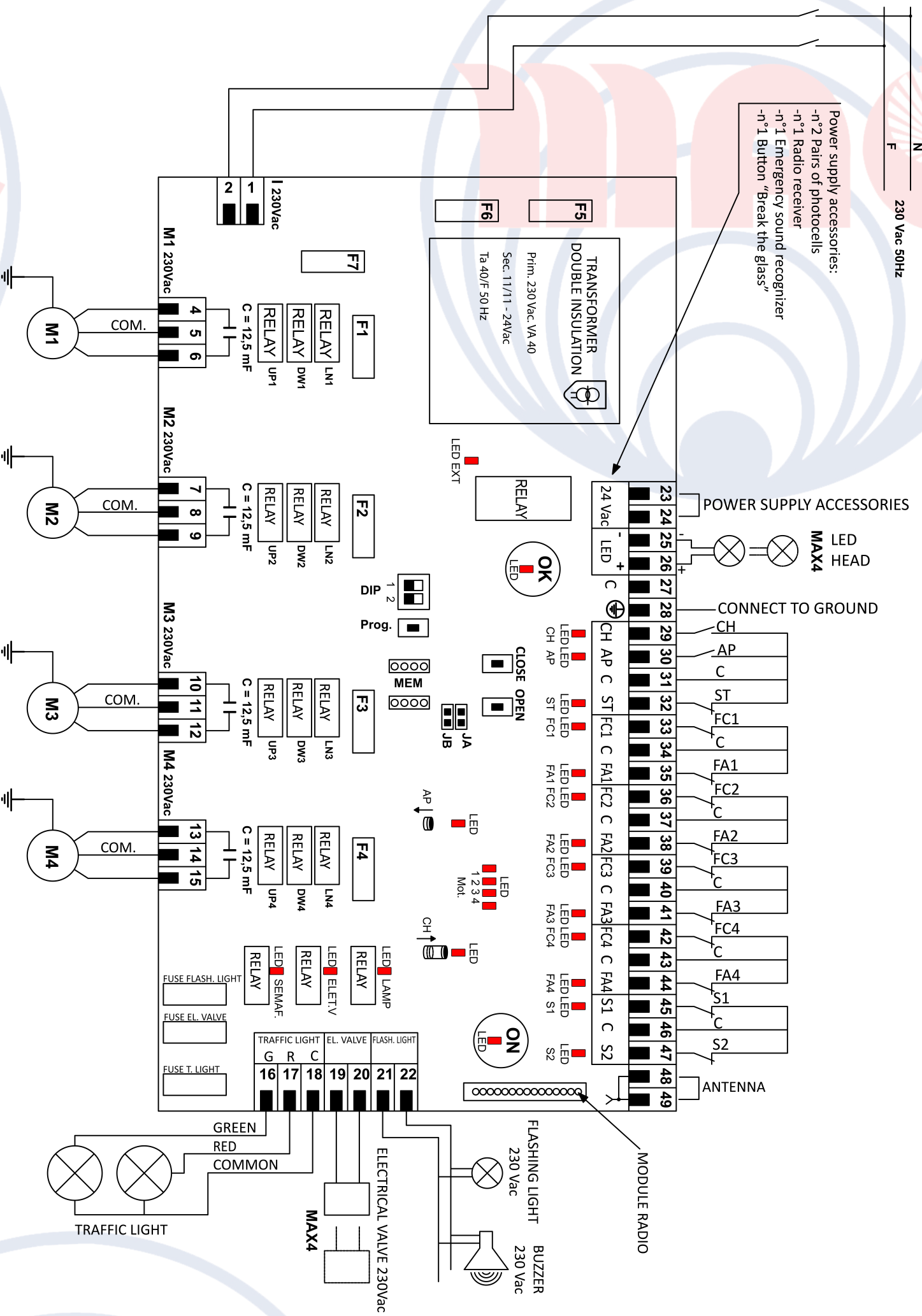

N  
F  
230 Vac 50Hz

